

Electrical Specifications

Impedance: 95 OHMS
 Center contacts: 5.0 MILIOHMS
 Insulation resistance: 5000 MEGA OHMS min.
 Dielectric break down: 1500 RMS-60Hz for 1 minute.
 Frequency range: 0 - 500 MHz
 Voltage rating: 500V peak.

Environment

Temperature: -40° To 80° C (-67° to 185° F)
 Humidity: 10% to 90% RH

Mechanical

Mating: Keyway polarization
 Connector durability: 250 mating cycles min.
 (no degradation in electrical parameters).

Materials

Male Contact: Silver Plated (Gold Flash available upon request)
 Female Contacts: Beryllium Copper Tin or Silver Plated
 Body: Copper alloy or die cast (Nickel Plated or IBM Approved Equivalent) Plastic Plug Body
 Procan UL94V-O
 Insulator: noryl

Note: use with IBM P/N 7362211 and Belden 9207 cable.

DESCRIPTION	BRTB	IBM
Brass Plug (Crimp Type, Gold Flash Contact)	3428-G	
Brass Plug (Crimp Type, Gold Flash Contact, Wide Slot)	3428-GW	
Brass Plug (Crimp Type, Silver Contact)	3428-S	
Brass Plug (Crimp Type, Silver Contact, Wide Slot)	3428-SW	
Brass Plug (Solder Type, Silver Contact)	3429-G	
Brass Plug (Solder Type, Silver Contact, Wide Slot)	3429-GW	
Brass Plug (Solder Type, Silver Crimp Contact)	3429-SC	
Brass Plug (Solder Type, Silver Contact)	3429-S	7362229
Brass Plug (Solder Type, Silver Contact, Wide Slot)	3429-SW	
Receptacle (Cable Mount Crimp Type)	3458	
Receptacle (Cable Mount Solder Type)	3459	6838959
Receptacle (Front Mount Die Cast)	3479	7362179
Receptacle (Rear Mount Die Cast)	3498	7364498

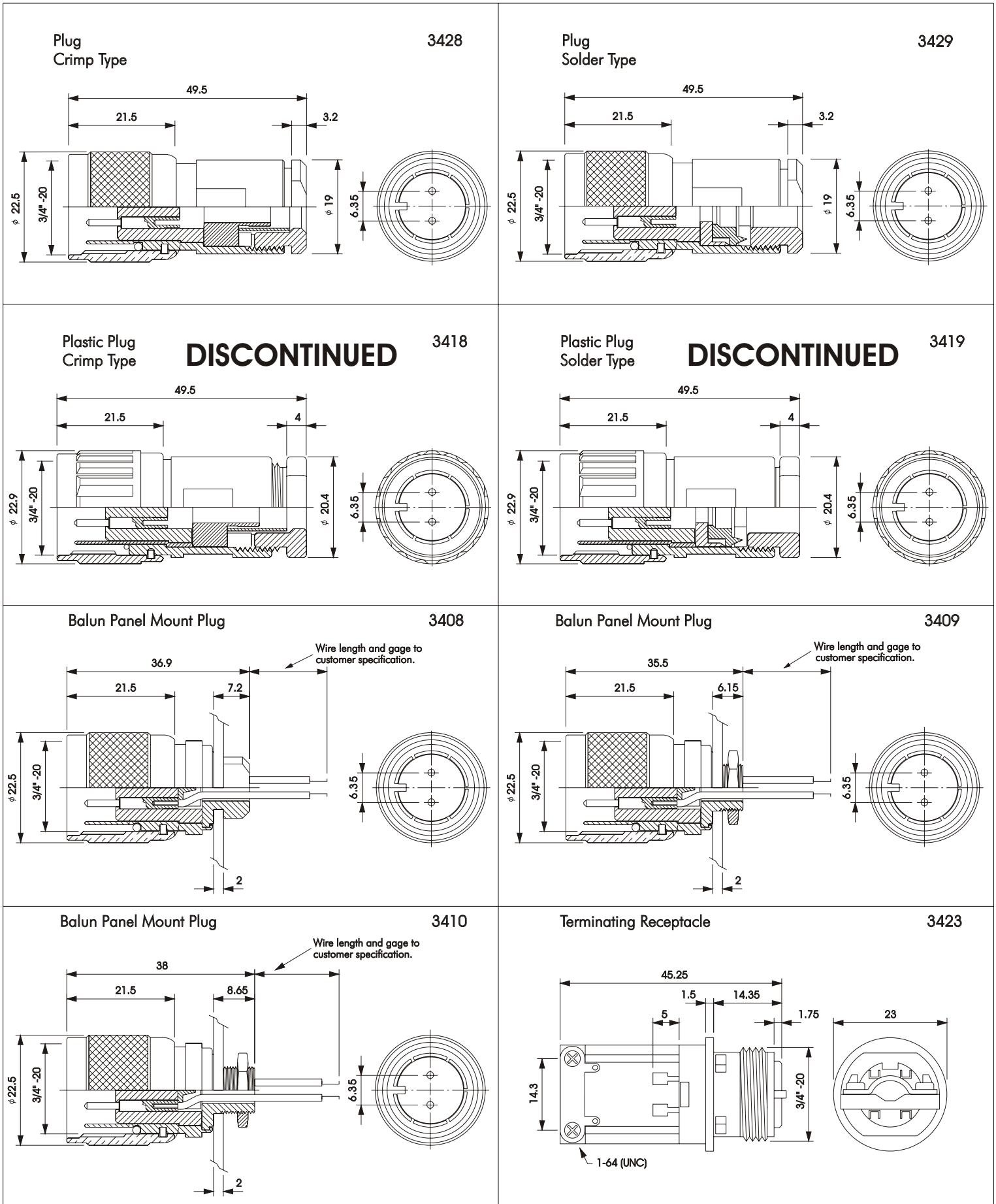

Cable Socket
Crimp Type

3458

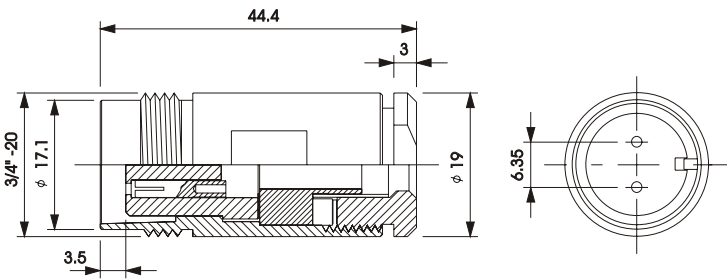

Cable Socket
Solder Type

3459

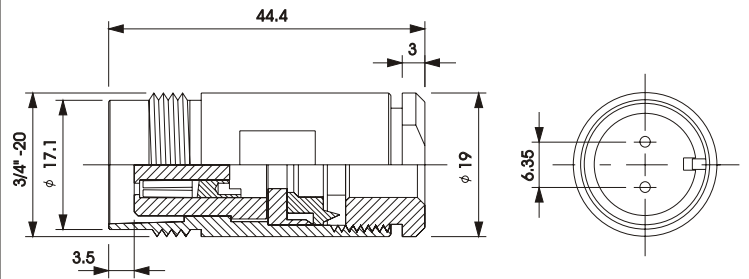

Straight Jack/Jack

DISCONTINUED

3430

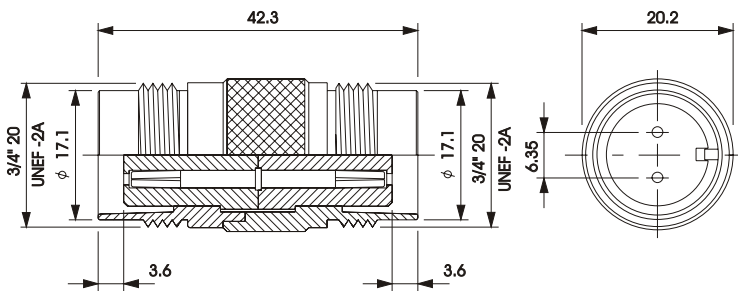

Straight Jack/Jack
With Boot (Insulated)

DISCONTINUED

3432

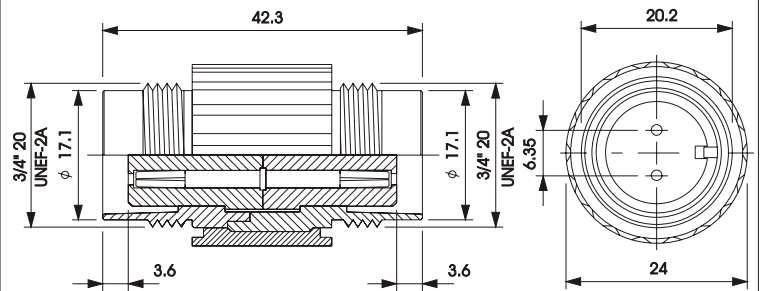

Panel Adaptor
Jack/Jack

DISCONTINUED

3431

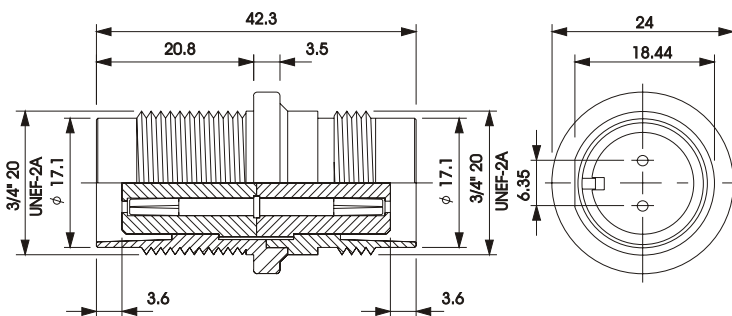

Receptacle Rear Mount

DISCONTINUED

3443

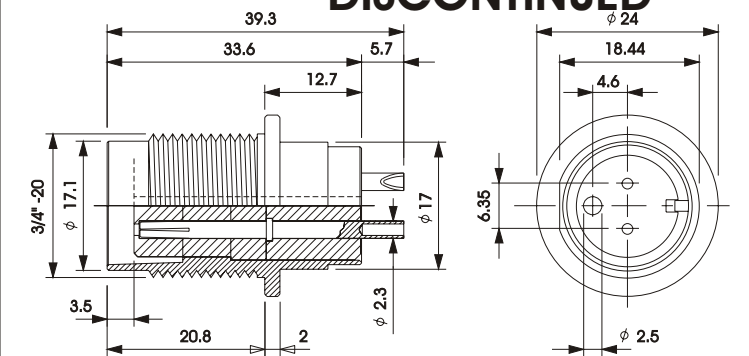

Receptacle Front Mount (Die Cast)
Receptacle Front Mount (Brass)

3479
3449

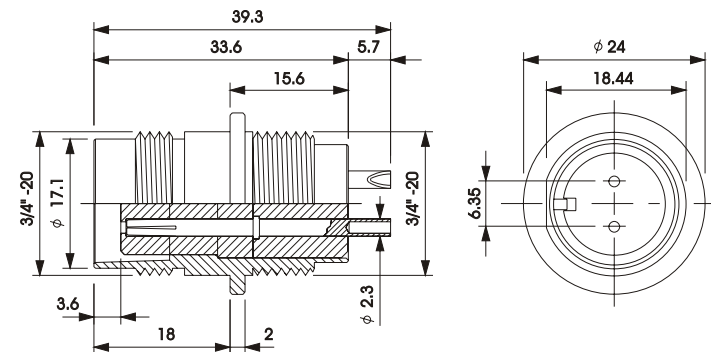

Receptacle Rear Mount (Die Cast)
Receptacle Rear Mount (Brass)

3498
3448

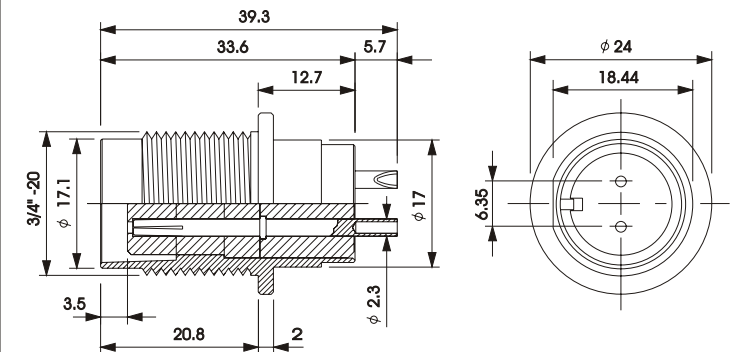

Crimp Type

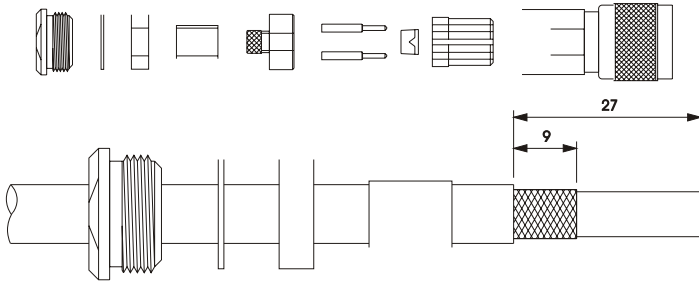

1. Cut the end of the cable squarely. 2. Slide clamp nut, washer, clamp gasket and ferrule over cable jacket.
3. Trim jacket and braid to dimension given.

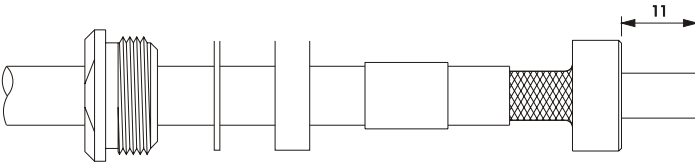

4. Slide sleeve under braid. Push crimp ferrule up to sleeve and crimp with crimp tool.

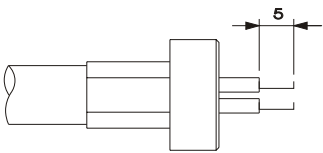

5. Trim cable core back to sleeve. 6. Strip centre conductors to dimensions given.

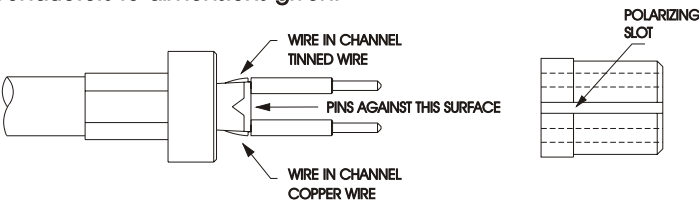

7. Fit contacts and crimp with crimp tool.
8. Place strain relief between conductors. Bend contacts over strain relief ensuring contacts rest on top surface of strain relief. 9. Slide insulator over contacts so that it butts against sleeve. Press all parts together.

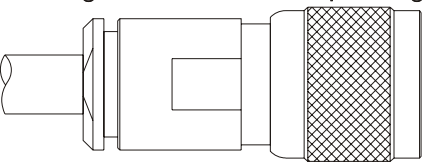

10. Insert assembly into connector body aligning polarizing slot in the insulator with polarizing pin inside the body. 11. Tighten nut to a torque of 5.7 - 6.8 NM preventing rotation of the cable during this operation.

Solder Type

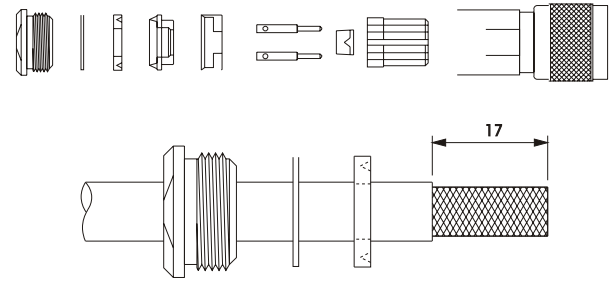

1. Cut the end of the cable squarely. 2. Slide clamp nut, washer, clamp gasket over cable jacket.

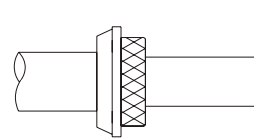

4. Slide braid clamp over braid so that its inner shoulder butts against cable jacket. Fan out braid, trim off excess and fold back over braid clamp.

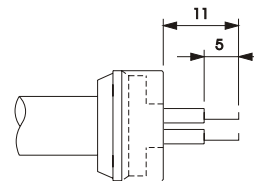

5. Slide sleeve over cable core and press against braid wires. Cut cable core flush to sleeve.
6. Strip centre conductors to dimension given.

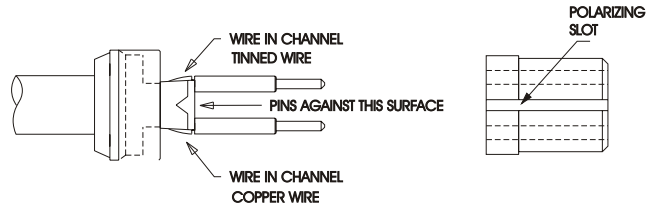

7. Fit contacts and solder with a low power iron avoiding excess solder or overheating. 8. Place strain relief between conductors. Bend contacts over strain relief ensuring contacts rest on top surface of strain relief. 9. Slide insulator over contacts so that it butts against sleeve. Press all parts together.

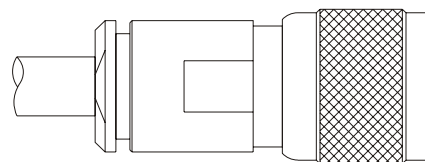





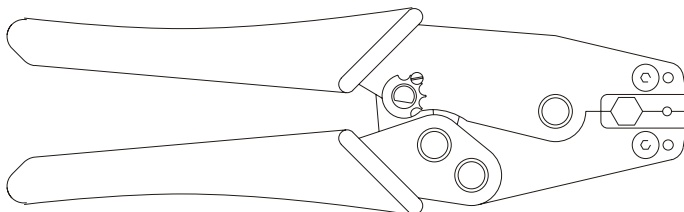





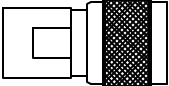

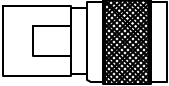
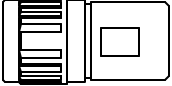











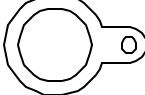



10. Insert assembly into connector body aligning polarizing slot in the insulator with polarizing pin inside the body. 11. Tighten nut to a torque of 5.7 - 6.8 NM preventing rotation of the cable during this operation.

CRIMP TOOL



CR340000

SPARE PARTS

	BRASS BODY 68600161		BODY 68600221		SMALL NUT 60500221
	BRASS BODY (WIDE SLOT) 68600161		PLASTIC BODY 68500260		CH 22 NUT 60500061
	BLACK INSULATOR 64600006		CLAMP GASKET (SOLDER) 60600461		WASHER WITH GROUND LUG 61500070
	BLACK INSULATOR (WIDE SLOT) 64500005		BRAID CLAMP 60600471		WASHER 61500081
	CLAMP GASKET (CRIMP) 60600661		RUBBER WASHER 63500030		WASHER 61500004
	FERRULE 60600681		METAL WASHER SOLDER 61500041		GROUNDING LUG 6150010
	RUBBER WASHER 63500020		SOLDER NUT 60600431		
	METAL WASHER CRIMP 61500051		SOLDER PIN GOLD FLASH 60600453		
	CRIMP NUT 60600481		SOLDER PIN SILVER 60600461		
	STRAIN RELIEF 64500006		PLASTIC CRIMP NUT 64500070		
	CRIMP PIN GOLD FLASH 60600503		PLASTIC SOLDER NUT 64500040		
	CRIMP PIN SILVER 60600601		CRIMP PIN FEMALE 60600171		
			SOLDER PIN FEMALE 60600191		